

APPROVED IN ACCORDANCE WITH THE EUROPEAN STANDARD 2014/34/EU - ATEX

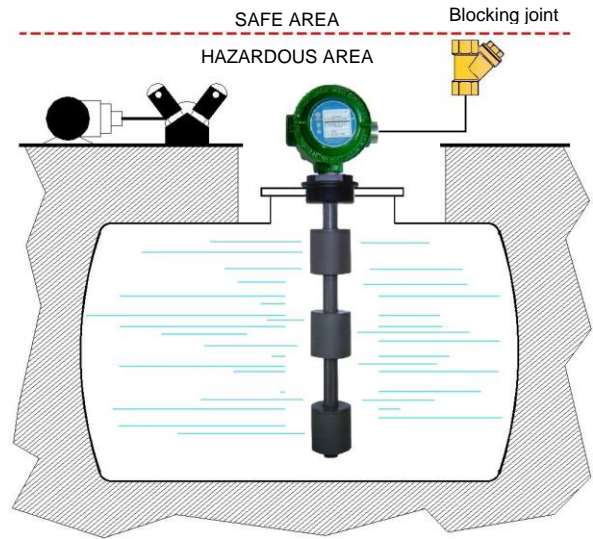

These instruments, explosion-proof certified **CESI 03 ATEX 272 Ext.2 II 1/2G Exdb IIB T5/T6 Ga/Gb**, are used to control the level of liquids or fuel in tanks, both underground and outdoors, installed in hazardous areas where flammable products are treated.



GENERAL CHARACTERISTICS

- **PVC – PP – PVDF**
- Up to 6 switch points.
- Up to 5 m length.
- Maximum working pressure 6 bar depending on used float.
- Executions up to 130°C on request (PVDF).
- Operating ambient temperature.
T6 -40/+40°C **T5** -40/+60°C
- Minimum degree of protection IP67.
- Built-in temperature sensors, on request.
 PT – PTC – NTC – Thermostat (thermoprotector)

FLOATS

Tab.1

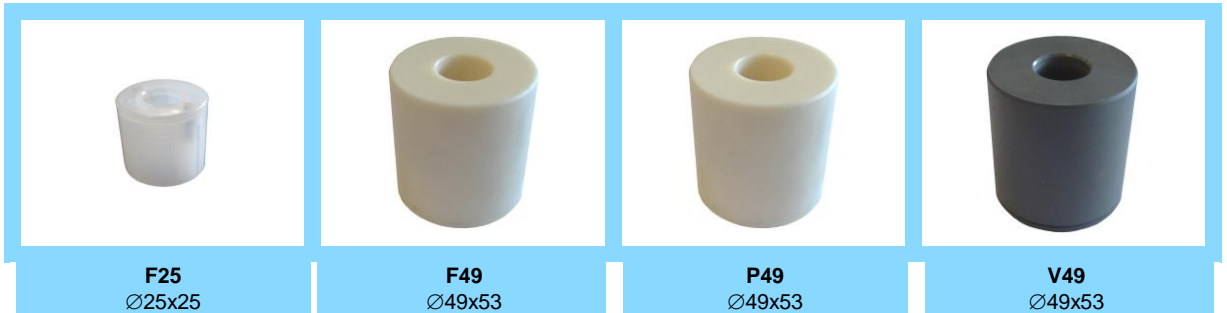

Material	PVDF				PP - Polypropylene				PVC			
Specific gravity	0,65				0,45				0,7			
Contact type	3	6D	4	6	4	6	4	6	4	6	4	6
Max N. of contacts	4	3	6	6	4	3	4	3	4	3	4	3
Max. bar	6				3				6			
Max. °C - Class	L = 100°C				D = 90°C				B = 60°C			
On request	N = 130°C				-				-			

ELECTRICAL CONTACTS

Tab.2

TYPE	POWER		VOLTAGE		CURRENT	
	VA	W	AC	DC	AC	DC
SPST 3	70	50	300	350	0,5	0,7
SPST 4	80	80	250	250	1,3	1,3
SPDT 6	60	60	230	230	1	1
SPDT 6D	20	20	150	150	0,5	0,5

ELECTRICAL OUTPUT

Tab.3

E1	IP66/67 Housing – Aluminum - Epoxy painted Max. 18 terminals
E3	IP66/67 Housing – AISI 316 St. steel Max. 18 terminals

Heatsink - see dimension (*) Temperature class **N**

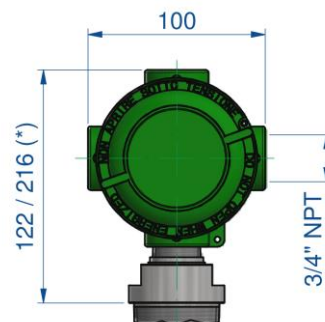

PROCESS CONNECTIONS

Tab.4

Float type	Installation from outside – available thread and flanges				
	25	32	50	DN50	DN65
	1"	1¼"	2"	Flange	Flange
F25	G-C-N	G-C-N	-	•	-
F49	-	-	G-C-N	-	•
P49	-	-	G-C-N	-	•
V49	-	-	G-C-N	-	•

Male thread

G	C	N
Parallel UNI 228/1	Conical UNI 7/1	Conical NPT

Available materials

V	P	F	S
PVC	PP	PVDF	AISI-316
On request			

DN = Available materials

V	S
PVC	AISI-316
On request	

FLANGES

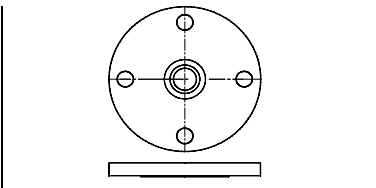

DN = Flanges UNI – DIN – ANSI

A Flanged connection
A1 Threaded connection

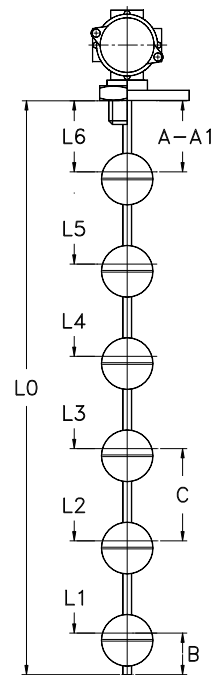

WIRING

Tab.5

I	Independent	Separately wired contacts	1	NO	Contacts status in no level conditions
C	Common	Common wired contacts	2	NC	
S	Custom	Contacts wired on request	3	SPDT	

SWITCH POINTS - minimum value in mm. Tab.6

The switch points L1 ÷ L6 are measured from the stop of the fitting or flange connection.
General tolerances on switch points ± 3 mm.

	Minimum distance in mm.							
	F25		F49		P49		V49	
A	20		40		40		40	
A1	35		60		60		60	
B	25		40		40		40	
C	50		80		80		80	
Contact type	3	6D	4	6	4	6	4	6
Max. N. contacts	4	3	6	6	4	3	4	3

OPTION – Built-in temperature sensor

On request, it is possible to install a temperature sensor located at the bottom of the rod inside the instrument.

PT100 – PT1000	PTC	NTC	TRP (Thermoprotector)
EN 60751 – IEC 751	Resistance at 25°C ≤ 500 Ω	Resistance at 25°C 2-5-10-50-100 KΩ	70°C ÷ 130°C - 10°C step
Classe B – A (a richiesta)	Temperature 60°C ÷ 130°C	Precision ± 5% / ± 3% (on request)	Precision ± 5% Differential 40°C

NOMENCLATURE

M2	V49	4	1300	V	50	G	V	E1	B	I22	L1÷L6	
•												Number of contacts S1 / M2÷M6
	•											Tab.1 Float
		•										Tab.2 Electrical contact
			•									- Total length = L0 in mm. (See drawing)
				•								Tab.4 Rod material
					•							Tab.4 Process connection dimension
						•						Tab.4 Process connection thread
							•					Tab.4 Process connection material
								•				Tab.3 Electrical output
									•			Tab.1 Temperature class
										•		Tab.5 Wiring and contact status
											•	Tab.6 Switch points (mm)

Request form

External mounting

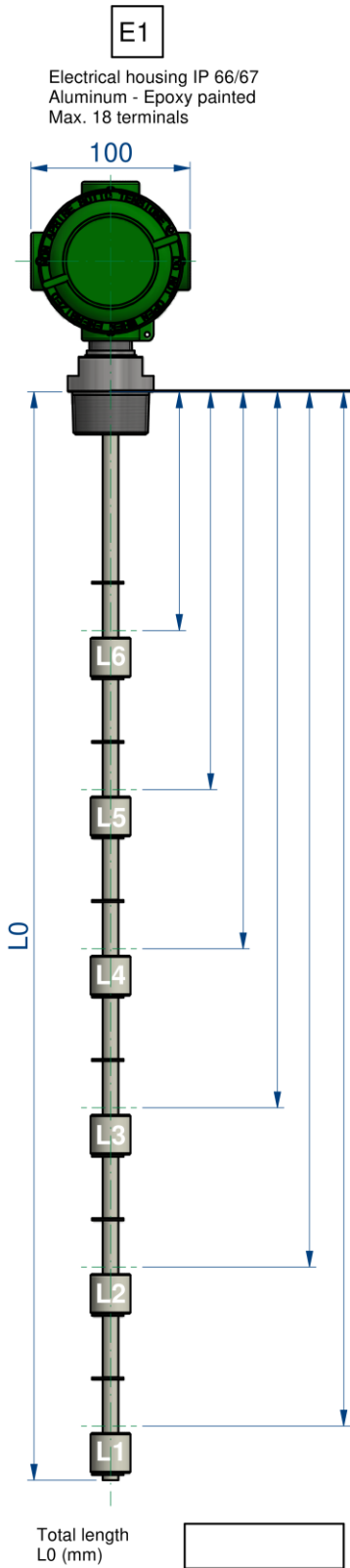

E1

Electrical housing IP 66/67
Aluminum - Epoxy painted
Max. 18 terminals

E3

Electrical housing IP 66/67
Stainless steel - AISI 316
Max. 18 terminals

STAINLESS STEEL

Liquid under control:

Specific gravity:

Maximum pressure:

Maximum temperature:

Approvals:

Exd GOST-R Ex

Process connection:

Threaded:..... Flanged:

Material:

Brass AISI-316 PVC PP PVDF

Wirings:

Independent contacts NO or NC (Max. 6 contacts)

Independent SPDT contacts (Max. 4 contacts)

Common wired NO or NC (Max. 6 contacts)

Common wired SPDT contacts (Max. 5 contacts)